

Replacement Insert Knife Instructions for 45° and 60° V-Groove

Amana Tool 45° #'s RC-1045, RC-1049 & RC-1145

Amana Tool 60° #'s RC-1108, RC-1148 & RC-1148-M



! WARNING!

For your safety, turn CNC machine off before replacing insert knife.

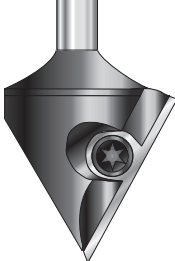
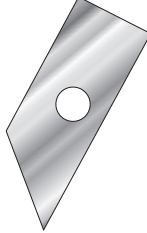

Must Wear leather gloves when inserting and releasing carbide knife from tool body.

Parts List

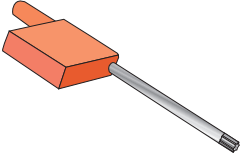
1	Before You Begin a. Wear leather gloves. b. Ensure CNC machine is turned off. c. Remove bit from CNC Collet.	Tool Body 	Replacement Insert Knife #RCK-56 or #RCK-350 	Torx Screw 	Torx Key 
---	--	--	---	---	---

2

Correct Order of Removing the Insert Knife

- Unfasten set screw by turning counter-clockwise.
- Remove the insert knife.
- Clean tool body and screw for dust buildup.

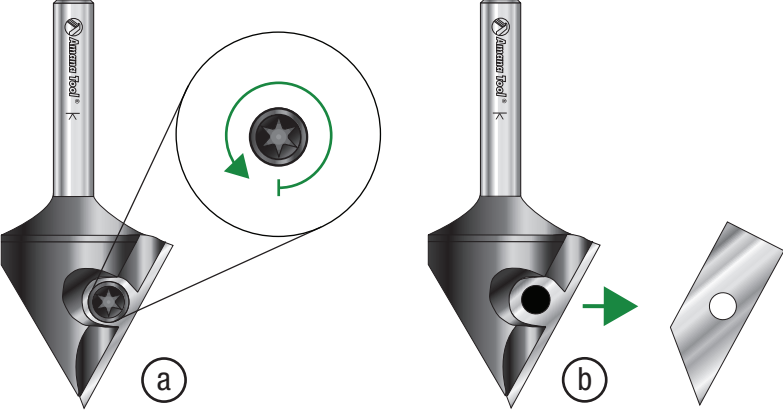

3

Correct Order of Inserting the Insert Knife

- Slide the insert knife left into the tool body slot.
- Align top of insert knife with the top of the tool body.
- Fasten screw firmly by turning clockwise.

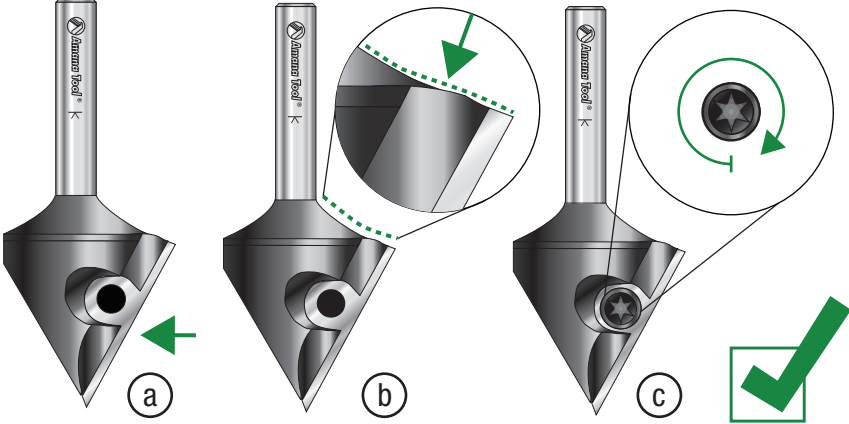

Instrucciones Para El Cambio De Insertos De Las Herramientas De 45° Y 60° Corte En V.

Amana Tool 45° #'s RC-1045, RC-1049 & RC-1145 / Amana Tool 60° #'s RC-1108, RC-1148 & RC-1148-M



⚠ ADVERTENCIA!

Para su seguridad, apague la maquina CNC antes cambiar el inserto.

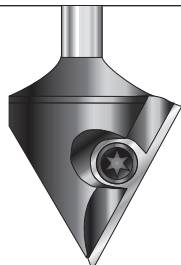
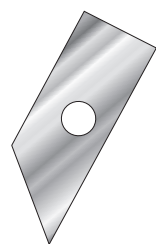

Debe usar guantes de cuero al insertar y liberar la cuchilla de carburo del cuerpo de la herramienta.

Lista de piezas

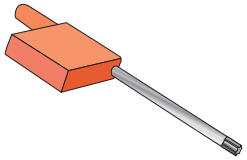
1	Antes de empezar a. Use guantes de cuero. b. Asegúrese de que la máquina CNC está apagada. c. Retire la broca de la pinza del CNC.	Cuerpo de la herramienta 	Cuchilla de repuesto #RCK-56 or #RCK-350 	Tornillo Torx 	Llave Torx 
---	--	---	--	--	---

2

Orden correcto de desmontaje la cuchilla de inserción

- Afloje el tornillo de fijación girando en sentido contrario a las agujas del reloj.
- Retire la cuchilla de inserción antigua.
- Limpié el cuerpo de la herramienta y el tornillo para evitar la acumulación de polvo.

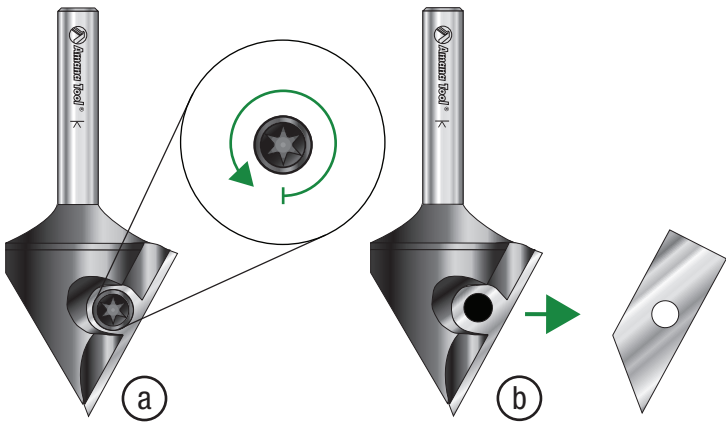

3

Orden correcto de inserción de la cuchilla de inserción

- Deslice la cuchilla de inserción hacia la izquierda en la ranura del ranura del cuerpo de la herramienta.
- Alinee la parte superior de la cuchilla de inserción con la parte superior del cuerpo de la herramienta.
- Apriete firmemente el tornillo girando en el sentido de las agujas del reloj.

